



#Friendly
#Committed #Competent
SERVICE



This is who we are

GROB-WERKE





Technology at its best

STEP INTO A GREEN FUTURE WITH US

At GROB, we strive for continuous progress and improvement. Not only do we strive to develop outstanding solutions and products for our customers, but we also seek to make a contribution to our environment and future generations. This is firmly anchored in our corporate philosophy and lived every day.

We therefore utilize photovoltaics and geothermal energy in our locations and support a wide variety of social projects. But we also place great emphasis on SUSTAINABILITY in our internal departments. Our products are based on the highest energy efficiency and regenerative drive systems. We integrate our supplier network in reducing the carbon footprint.



OUR PRODUCT RANGE

#MachiningTechnology #UniversalMachiningCenters
#AssemblyPlants #Electromobility
#Automation #AdditiveManufacturing #Digitalization
#NewAndQualityCheckedUsedMachines #Service

Concentrated competence worldwide

INTELLIGENT TECHNOLOGY IS HUMAN

For generations, we at GROB have lived and experienced this principle by making customer requirements the focus of our work. The result is sophisticated technology creating more efficient production processes worldwide and delivering highest quality.



RESEARCH & DEVELOPMENT

With a high degree of creativity and technical intuition, as well as the best engineering expertise, our developers have worked hard to earn the reputation of being a technology leader.



ASSEMBLY

From pre-assembly to machine assembly to process commissioning – our employees demonstrate their expertise with optimally coordinated workflows.



ENGINEERING

With method development and structured problem solving, our employees in Engineering develop innovative concepts representing milestones for precision, dynamics, and reliability.



COMMISSIONING

With simulation techniques and virtual commissioning, we achieve the highest adherence to delivery dates and product quality.



PRODUCTION

The high degree of vertical integration along the entire value creation chain, numerous machining technologies and our employees' distinctive specialist knowledge create the best conditions for state-of-the-art production.



TECHNICAL APPLICATION CENTERS

Our production plants in Germany, Brazil, the USA, China, Italy and India have technical application centers for the machining and electromobility sectors, where our customers can experience GROB technologies up close.

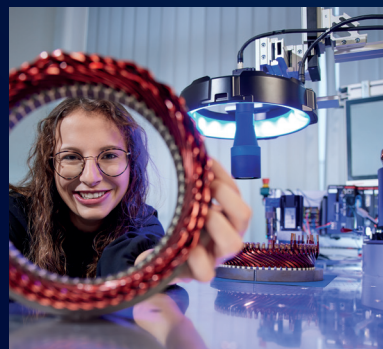
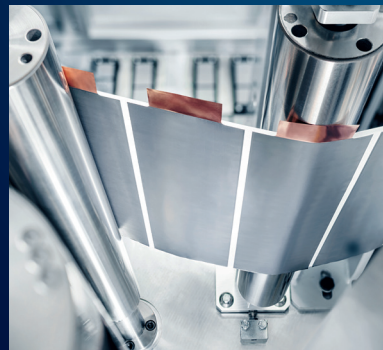
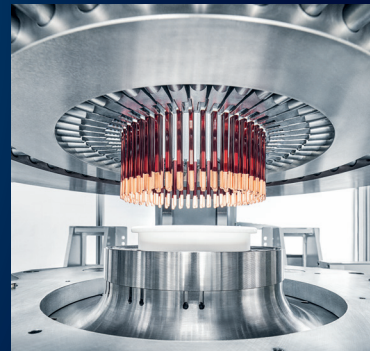
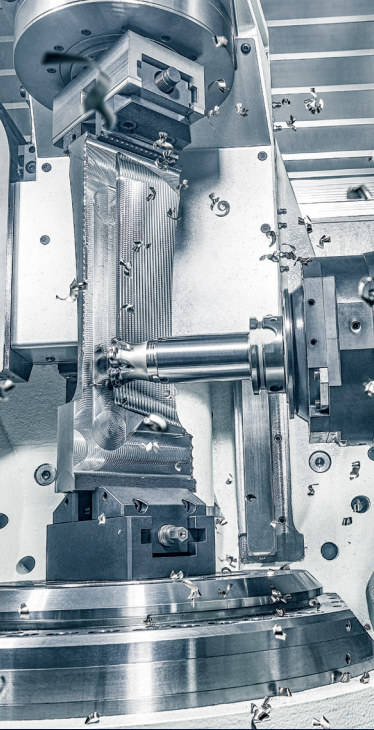

Friendly, committed, competent

GROB SERVICE

From our 24-hour service and comprehensive range of spare parts and training courses to professional machine preventive maintenance: The GROB service spectrum offers you a comprehensive range of services and is available to you worldwide thanks to our global production facilities and service branches.

24/7 SUPPORT

Service hotline

SERVICE AGREEMENTS

Remote support and Smart production reliability

Preventive maintenance and maintenance agreement

MATERIAL SUPPLY

Spare parts

Risk analysis

GROB⁴Care webshop

Special equipment

Special equipment box

OVERHAUL AND MODERNIZATION

Condition analysis

Optimization analysis

Overhaul

PCU retrofit

NCU retrofit

Non-machining time optimization

Retrofitting options

Automation solutions

MOTORIZED SPINDLE SERVICE

IN-HOUSE REPAIRS

Assembly and part repairs

Repair service for electronic systems

Scheduled vs. unscheduled repairs

FIELD SERVICE

Production support

Machine relocation

DIGITALIZATION

GROB-NET⁴Industry

TECHNICAL ACADEMY

GROB Technical Academy

Training-on-the-job

GROB Campus

Skill gap analysis



EFFICIENCY &
SUSTAINABILITY



PRODUCTION SAFETY



QUALITY &
OUTPUT



Highest quality and outstanding service

GOOD SERVICE KNOWS NO BOUNDS

Our top priority is maximum productivity for your machines. Would you like to have someone there for you around the clock whose most important task is solving your problems? Would you like maximum machine availability without your spare part warehousing costs going sky-high?

Our decades of experience, excellent quality and reliability as one of the world's leading manufacturers of machining centers and complex production and assembly systems make us your constant and reliable partner: All over the world and for the entire lifespan of your machine.

GROB SERVICE – AS VERSATILE AS YOUR REQUIREMENTS!

It makes no difference to us whether your GROB machine is old or new, or whether you have a small or large machine fleet. You as the customer – with your unique requirements, processes and challenges – are our number one priority at all times. We address your individual challenges and are exactly the partner you need.

OUR PROMISE TO YOU:

- + An advisor who assists with compiling an individual spare and wear parts package to suit you
- + A trainer who helps you get even more from your machines
- + An innovator who works with you to realize and drive Industry 4.0 projects
- + A specialist who puts your machine through its paces and achieves the same production accuracy you had on the very first day



Gain new insights

GROB PRODUCT STORIES

EXPERIENCE OUR PRODUCTS AND INNOVATIONS

- + GROB⁴Care webshop
- + Preventive maintenance & inspection
- + GROB Technical Academy
- + Express production
- + and much more ...



CLICK HERE FOR OUR
GROB PRODUCT STORIES ON YOUTUBE





You can count on us!
24/7 SUPPORT

Your direct contact for prompt and competent assistance: The employees of our service hotline are at your disposal around the clock in the event of malfunctions and to answer technical questions. If necessary, our highly qualified service staff will quickly come to you with the right tools and measuring equipment upon request via our hotline.



OUR SERVICE PORTFOLIO
#24/7Support #MaterialSupply
#MachineInspection

You can reach us 24 hours a day!

SERVICE HOTLINE

BASIC SERVICES

Would you like to have someone whose most important task is solving your problems?
We are exactly such a partner: **Listening – Finding solutions – Getting it done.**



GROB service hotline

Highly qualified technicians are there for you 24 hours a day, 7 days a week, 360 days a year.



Your concerns are important to us

Skilled contacts for optimal knowledge transfer.



We provide a full service package

Remote machine diagnostics and initiation of further steps to quickly put your GROB machine back into operation.



We offer a network of rapid response technicians

They are quick to arrive on site – including spare parts and special tools as required.

YOUR BENEFITS

- + Fast problem-solving by highly qualified technicians
- + No need to own special tools
- + Perfect coordination of material provision and deployment of our service technicians
- + Fast restart of your GROB machine

**WE ARE ALWAYS KEEN TO
LISTEN TO WHAT YOU HAVE TO SAY!**

24/7 service hotline: **+49 (8261) 996-777** or via e-mail to **hotline.service@grob.de**



International service hotlines

Our international service hotlines are there to help at the office hours indicated!
If you have questions or concerns, feel free to get in touch with us at one of the following locations:

GROB USA

Service hotline

Tel. +1 (419) 369-2610
Monday-Friday: 24 hours a day
Saturday-Sunday: 7 am to 3:30 pm
customerservice@grobssystem.com

GROB BRAZIL

Service hotline

Tel. +55 (11) 4367-9278
Monday-Friday: 7 am to 8 pm
Saturday-Sunday: 8 am to 8 pm
service@grob.com.br

GROB ITALY

Service hotline

Tel. +39 (011) 934-8292
Monday-Friday: 8 am to 5 pm
service.italia@grobgroup.com

GROB CHINA

Service hotline

Tel. +86 (411) 3926-6888
Monday-Sunday: 7 am to 9 pm
gcd-service@grob.com.cn

Service locations in the DACH region

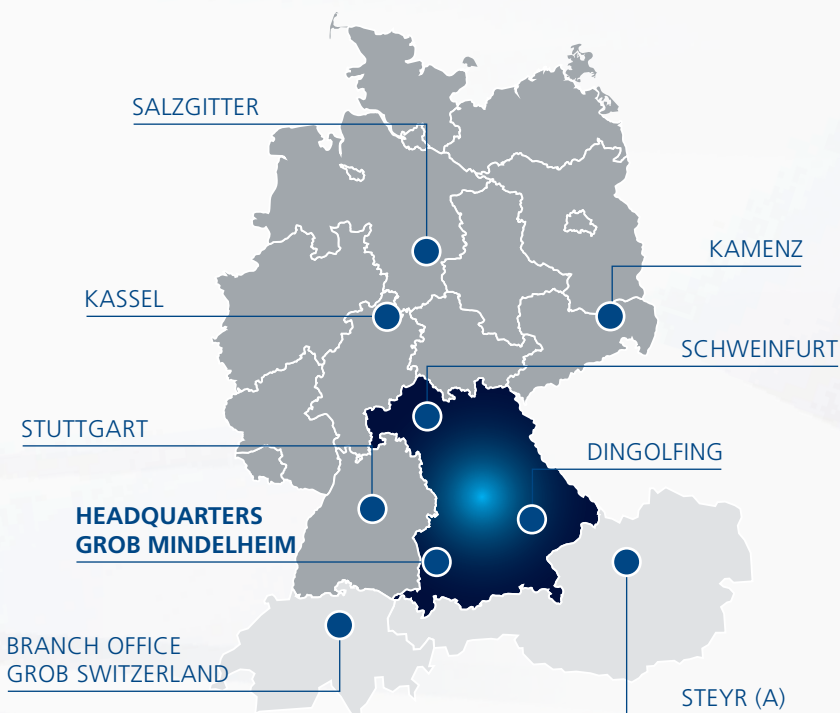





*Select the package
that suits you!*

SERVICE AGREEMENTS

Our service agreements lay the foundation for consistently high productivity. Whether through support with remote machine diagnostics as part of remote support or with the GROB Smart production reliability all-round carefree package: Choose the service agreement that suits you perfectly from three packages!

- ⊕ Rapid assistance thanks to professional remote diagnostics – reduction in on-site deployment by around 80%
- ⊕ Reduction in follow-up costs and minimization of unscheduled downtimes – with annual preventive maintenance and inspection
- ⊕ Long-term value retention of your machine with our service agreements
- ⊕ Take the Smart step and combine all the benefits of Remote Support and the preventive maintenance agreement in a single package



OUR SERVICE PORTFOLIO

#RemoteSupport #ServiceLevelAgreement
#PreventiveMaintenance&Inspection
#ProductionReliability

Your foundation for consistently high productivity

REMOTE SUPPORT & SMART PRODUCTION RELIABILITY

UP TO 80 % FEWER ON-SITE TECHNICIAN ASSIGNMENTS!

Remote machine diagnostics supports the technical service consultant with fault diagnostics and any required fault clearance as well as to prepare for and support on-site service assignments.

- + Online access to applications and operating systems
- + Remote diagnostics for fault detection within the NC and PLC
- + Data transmission to exchange relevant system files directly to the control system
- + Remote administration to eliminate errors
- + Dialog mode for communication

WANT TO CONTINUE TO MAKE USE OF REMOTE MACHINE DIAGNOSTICS
EVEN AFTER YOUR WARRANTY EXPIRES?

Arrange a Remote Support Service Agreement now!



- + 24/7 GROB Service Hotline
- + Flat rate for remote machine diagnostics
- + Spare part delivery the following working day

SMART PRODUCTION RELIABILITY BENEFITS PACKAGE

- + Benefits of a Remote Support Service Agreement
- + Benefits of a Maintenance Agreement
- + **7.0 %** loyalty discount on spare parts
- + **2.0 %** loyalty discount on the hourly service rate



We look forward together

PREVENTIVE MAINTENANCE AND MAINTENANCE AGREEMENT

MACHINE-SPECIFIC GROB INSPECTION

Inspection of

- + safety functions and safeguards
- + hydraulic system, lines, pressure setting, and tightness
- + lubrication, chip conveyor, and pneumatic system
- + spindle cooling, filter, electrical cabinet fan
- + electrical lines, fluid hoses, and measuring systems
- + linear guides, ball screws, drives of all axes
- + pallet changer, tool change group
- + additional tool magazine

Check via

- + geometry: mandrel position, radial and axial runout
- + rotating union
- + pull-in force measurement

INDIVIDUAL EXTENSION

- + Preventive maintenance and inspection for your automation solutions by GROB
- + Additional options such as ballbar measurement upon request

GROB PREVENTIVE MAINTENANCE

- + Performance of preventive maintenance measures based on running performance and time including package with original wear parts and professional replacement
- + The wear parts package includes: Additional and bedway wiper, motorized spindle groove ring, tool change system brush, linear encoder system filter element



WANT MORE THAN JUST PREVENTIVE MAINTENANCE?
A **preventive maintenance agreement** offers you benefits such as a 15% discount on preventive maintenance as well as an additional 5% loyalty discount on spare parts.





*95 percent availability
of spare parts*

MATERIAL SUPPLY

Whether through our express production, GROB⁴Care, or the GROB special equipment: With our flexible, fast, and comprehensive supply of spare parts, we ensure your production process reliability and smooth production. Benefit from our spare parts availability of around 95 percent and take advantage of fast delivery with express delivery or special delivery!

- ✦ Spare parts
- ✦ Risk analysis
- ✦ GROB⁴Care webshop
- ✦ Special equipment



OUR SERVICE PORTFOLIO

#SparePartsWarehouse #ExpressProduction
#GeneralOverhaul #SpecialEquipment

For optimal supply

SPARE PARTS

We store spare parts for you at nine different locations worldwide. A high level of vertical integration, a high degree of standardization, and customer-oriented supply concepts guarantee that you receive the spare and wear parts you need on time.

- + GROB Express: Over 2,000 materials of all product groups are available from stock. The materials leave the warehouse within 24 hours or on the same day if necessary.
- + Safety and reliability thanks to genuine manufacturer-quality spare parts.
- + Electrical components such as drives and power modules can also be repaired by our professional partners within 24 hours as and when required.

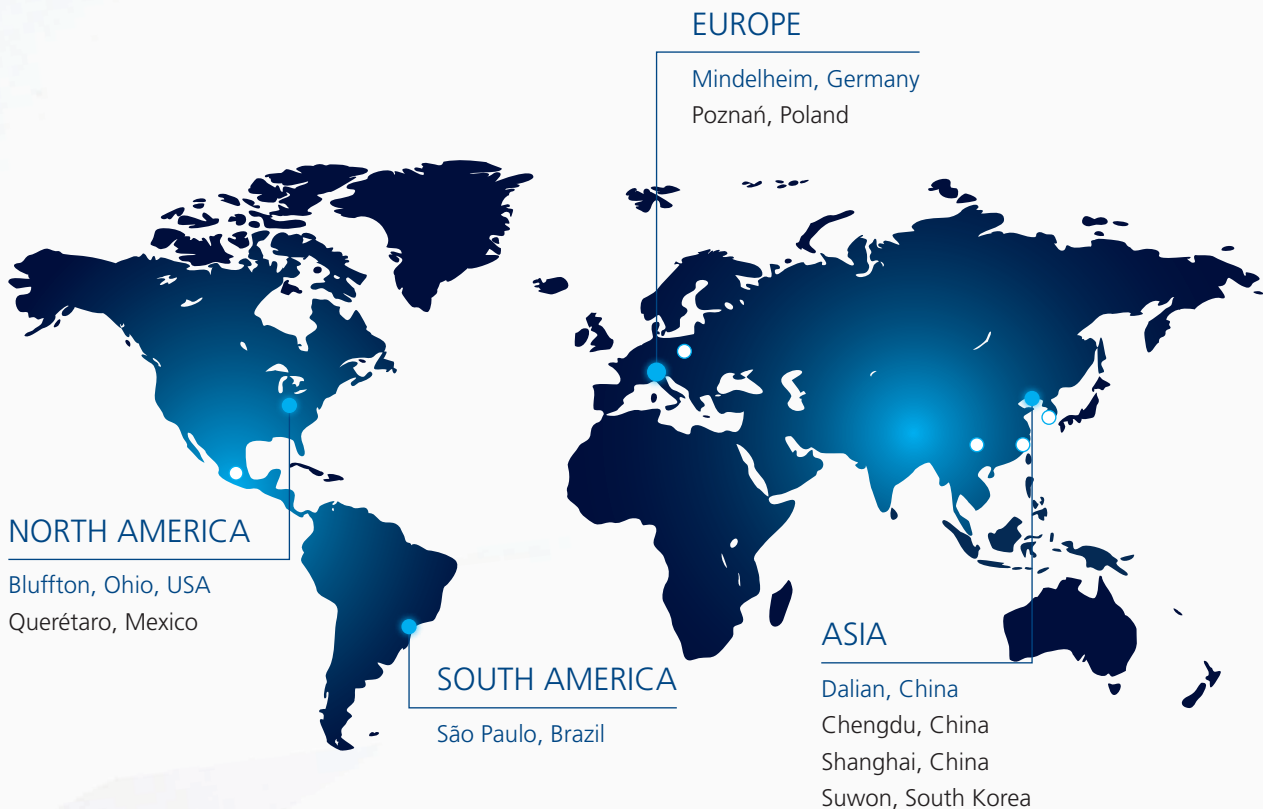

EXPRESS PRODUCTION – WHEN EVERY MINUTE COUNTS

We produce the spare part you urgently need as quickly as possible in-house and send it out to you as a special delivery. **Benefit from up to 90% faster delivery times!**





PACKAGES PUT TOGETHER FOR YOU BY EXPERTS FOR OPTIMAL SPARE PARTS SUPPLY

SPARE PARTS PACKAGES				
CONTENTS	PACKAGE 1	PACKAGE 2	PACKAGE 3	PACKAGE 4
	Preventive maintenance-related parts	Spare parts for motorized spindle	Complex parts, highly stressed	Flexible manufacturing systems
Groove ring, brush, grinder, filter element, toothed belt, lubrication pinion	•	•	•	•
Gripper, clamp lifter, bellows, cover, safety switch, pressure switch, clamping unit, coupling system, rotating union, clamping set	—	•	•	•
Safety brake, ball screw, rail systems	—	—	•	•
Rotary encoder system, linear encoder system, brush unit, parts in contact with the component, other recommended spare parts	—	—	—	•



W/T PACKAGE

Parts in contact with the component
Type W: 1x wear part, type Z: 1x spare part



CABLE PACKAGE

Contains 1 unit of each installed cable to provide a complete backup in case of cable defects

Your optimal stocking strategy

RISK ANALYSIS

GREATER PRODUCTION RELIABILITY IN JUST 4 STEPS

- 1. Check the main drivers of a risk of failure**

Possible drivers of a risk of failure may be external influences on the material such as wear and mechanical stresses or the installation location of the materials.
- 2. Classification into 4 damage classes**

A damage class is comprised of the spare parts classification and the bottleneck station. Criticality classes 1, 2, S, W, and T describe spare parts that have a high or medium priority or that are wear parts, safety parts, or parts in contact with the component. Criticality classes 3, 9, and C include spare parts with a low priority, wear parts **without** a GROB spare part marking or consumables. The existence of a bottleneck is derived from the number of machines in the OP.
- 3. Preparation of a customized, free quotation based on your needs and requirements**

We work together with you to prepare a quotation that considers our needs as well as your personal preferences and wishes.
- 4. Ordering and subsequent stocking**

The type of stocking depends on the damage class determined beforehand. For instance, stocking is required for damage class E1, while stocking is possible but not necessary for spare parts in damage class E4.

SAVE UP TO 9 HOURS

... in the repair of assemblies compared to individual spare parts.

- + Shorter installation times
- + "Plug & Produce" capability
- + Fewer downtimes



OUR APPROACH: MAIN DRIVERS OF THE RISK OF FAILURE OF MATERIALS

RISK ANALYSIS		
	CRITICAL	NON-CRITICAL
EXTERNAL STRESS Spare parts classification	1, 2, S, W, T + Spare parts (high or medium priority) + Wear parts + Safety parts + Parts in contact with the component	3, 9, C + Spare parts (low priority) + Wear parts (no GROB spare part marking) + Consumable
INSTALLATION LOCATION Bottleneck station	Yes A single machine is present in the OP. Its failure leads to a complete failure of the production line.	No Several machines are present in the OP.

RESULT OF THE RISK ANALYSIS:
 EVERY MATERIAL IS ASSIGNED TO A DAMAGE CLASS.

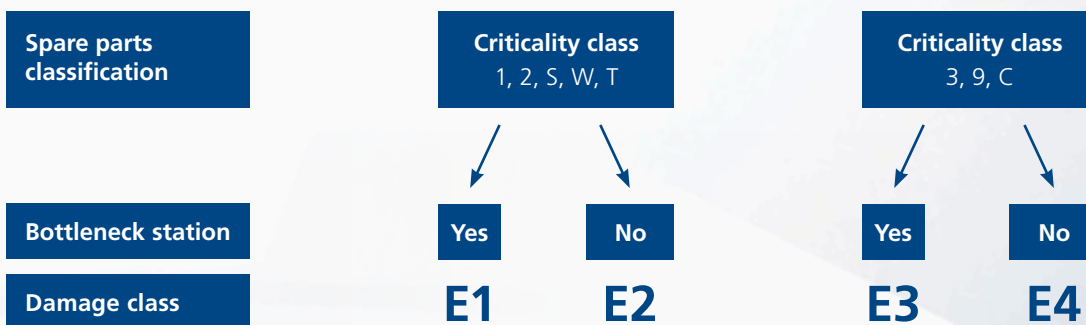

E1, E2 Cover demand for ongoing maintenance:
 Urgent stocking recommended

E4 Cover unplanned failures:
 Stocking recommended for repairs

E3 Cover unplanned failures:
 Stocking recommended for repairs

More than just a webshop

GROB⁴CARE WEBSHOP

Our service and maintenance portal not only gives you access to an interactive spare parts catalog, including parts lists and technical drawings, you can also conveniently order spare parts online: worldwide, at any time. GROB⁴Care is the platform for maintenance, scheduling and purchasing.

- ⊕ Display of your GROB machines and systems
- ⊕ Spare parts inquiry and ordering process
- ⊕ Simple integration into your ERP system
- ⊕ Availability of spare and wear parts via stock queries in real time
- ⊕ Display of your prices and discounts via real-time queries

The benefits to you as a customer

ORDER SPARE PARTS ONLINE CONVENIENTLY 24/7

- ⊕ Through real-time queries you can have an overview of the warehouse stock, your individual prices and your discounts at all times. Have a machine standstill and are in urgent need of a spare part? Good to know that you have access to all important information at any time, day and night, and can quickly and easily submit express orders.

PROCESS RELIABILITY THANKS TO THE HIGHEST DEGREE OF CUSTOMIZATION

- ⊕ Every customer is unique. This applies not only to the produced parts, but also especially to internal processes and workflows. GROB⁴Care allows you to show your individual release and approval process directly, and also to assign various permissions and budgets. Should the maintenance department be able to order spare parts up to a value of €2,000 per month? GROB⁴Care allows you to make this setting extremely easily, so you benefit from absolute process reliability.



The benefits to you as a maintenance technician

EVERYTHING AT A GLANCE

- ⊕ The webshop is tailored to your specific needs: Your own GROB machines and systems including parts lists, drawings and technical documentation are displayed in GROB⁴Care. The integrated catalog and highly efficient search tools allow you to find spare parts much faster than through the conventional procedure. This saves you valuable time and, when it comes to a machine standstill, irritation and money.

DIGITAL PLANNING SUPPORT

- ⊕ GROB⁴Care supports you with watch lists when planning overhauls and preventive maintenance activities. Add spare and wear parts to your shopping cart and call it up again at a later time. GROB⁴Care makes sure that nothing goes astray and that you have all data at hand at all times.

Tracking function **NEW!**

The tracking function lets you track your delivery. You know exactly when your ordered parts arrive. This supports greater planning certainty and provides a better overview of the status of your order.

Test the tracking function now!



TESTIMONIAL – SaarOTEC GmbH

We prefer to use the spare parts catalog in the GROB⁴Care webshop. We can interactively find specific spare parts for our machines in the digital part drawings.

The part drawings of our machines can easily be downloaded as PDF files. This way we have everything in digital form.



The right package for everyone

SPECIAL EQUIPMENT

Our high-quality special tools and measuring instruments allow you to inspect your GROB machine yourself and to replace components quickly and safely with your own experience. Please contact us, and we will be pleased to provide you with a set of special tools to suit your requirements. A training course held by our highly qualified employees will help you to use these special tools correctly.

- ⊕ Efficient preventive maintenance and repairs for your GROB machine
- ⊕ Repairs and inspections by your own personnel
- ⊕ Shortest possible machine downtimes



You can find more details on the special equipment in our separate special equipment brochure.

TAKE MATTERS INTO YOUR OWN HANDS!

If you can do it yourself, we will provide you with the tools you require to inspect your GROB machines and replace parts.



As versatile as your requirements

SPECIAL EQUIPMENT BOX

The box and its contents can be requested and ordered individually, specific to the machine type.

USB STICK

Documentation of all operations



REFERENCE TOOL HOLDER

Determination of the spindle zero degree position



ASSEMBLY AID FOR THE SEALING RING

Lip seal installation in the clamping set



HOLDER PLATE

Geometry measurement



TAPER WIPER

Cleaning of the tool holder on the motorized spindle



ARTICULATED TRIPOD

Geometry measurement



MIRROR

Auxiliary equipment



LEVER TYPE DIAL INDICATOR, 0.002 MM

Geometry measurement



*The special equipment pieces displayed are examples. You can find the entire product range for the box contents in our equipment catalog.





In good hands

OVERHAUL AND MODERNIZATION

From flexible condition analysis to retrofit measures and upgrades – you're in good hands with us! We take over the professional and fast check and optimization of your machines and systems.

- ✦ Quality & safety
- ✦ Speed
- ✦ Exclusivity



OUR SERVICE PORTFOLIO

#ConditionAnalysis #Overhaul #Retrofit
#Non-machiningTimeOptimization #Upgrade
#PCURetrofit

Reliability and accuracy are what count

CONDITION ANALYSIS

The GROB condition analysis shows you what needs to be done to restore trouble-free production once again. Whether after a machine crash, in case of tolerance deviations, or to define the extent of a potential overhaul – one of the analysis packages or a condition analysis tailored to your needs will identify the causes and suggest suitable remedies. To meet every demand, machines are inspected for functionality, quality, precision, and output.

- + Knowledge of the machine's condition and fault causes
- + Sound basis for decisions on modification measures, machine overhauls and modernizations
- + Reliable planning of the machine's future output
- + Risk minimization if older machines continue to be used



WOULD YOU LIKE TO KNOW WHAT'S GOING ON WITH YOUR MACHINE?

With you, we check your GROB machine thoroughly to find the best solution for possible overhauls, correction or modification measures.





THE FLEXIBLE GROB CONDITION ANALYSIS: ALL PACKAGES AT A GLANCE

Ahead of any condition analysis, we meet with you to hold an in-depth discussion to precisely understand your needs and identify an inspection scope to suit you. All results are professionally prepared and documented. We then evaluate the results and derive the necessary measures, including possible part recommendations.

ANALYSIS PACKAGES	NEW!		
	<i>Protection of output and spindle</i>	<i>Protection of production quality by means of geometry testing</i>	<i>Full service package to prevent loss of production</i>
	TOOL CHANGE CHECK, 6h*	GEO CHECK, 7h*	ALL-ROUND CHECK, 16h*
Gathering machine-related data	•	•	•
Motorized spindle geometry	•	•	•
Renishaw ballbar measurement	—	•	•
Assessment according to tool change check report	•	—	—
Assessment according to all-round check report	—	—	•
Discussion of results and steps to take	•	•	•

* Depending on the machine type

Reliability and accuracy are what count

CONDITION ANALYSIS

WHY YOU SHOULD CONDUCT THE CONDITION ANALYSIS TOGETHER WITH US!



Provision of expensive special tools and measuring equipment

Examples: Special equipment for measuring the tilting tolerance and circumferential backlash of the tool change gripper.



Reduction of inspection times by our specialists

We all know that time is money. So we make every movement count.



Detailed status report

Individual recommendation of corrective actions and optimization potential.



Safety thanks to comprehensive experience

Benefit from manufacturer know-how.

ANALYSIS OF MECHANICAL AND ELECTRICAL SYSTEMS COMBINED

TOOL CHANGE CHECK, 6h

GEO CHECK, 7h

ALL-ROUND CHECK, 16h



OPTIMIZATION ANALYSIS

- ⊕ Analysis of **software, hardware, and non-machining time**
- ⊕ Alarm analysis (alarm log, crash log, history of the GSD)
- ⊕ Check for upgrade possibilities (software, cycles, energy savings)
- ⊕ Use of energy-saving and powerful components
- ⊕ Non-machining time analysis including creation of G-Trace

→ IMPROVEMENT OF SYSTEM AVAILABILITY, PART OUTPUT, AND IT SECURITY!

We help realize your full potential

OPTIMIZATION ANALYSIS

THREE GOOD REASONS FOR AN OPTIMIZATION ANALYSIS

- + Potential of improving your machine performance
- + Fewer faults
- + Implementation without extended production downtime



DETAILED ANALYSIS REPORT

With suggestions for possible optimization measures in terms of

- + system availability
- + part output
- + spare part availability
- + energy efficiency
- + upgrade possibilities

IDENTIFICATION OF WAITING AND NON-MACHINING TIMES THAT CAN BE REDUCED

Includes a discussion of results and steps to take, as well as the subsequent quote preparation

WOULD YOU LIKE TO KNOW WHAT'S GOING ON WITH YOUR MACHINE?

With you, we check your GROB machine thoroughly to find the best solution for possible overhauls, correction or modification measures.



Manufacturing accuracy, just like on day one

OVERHAUL

MACHINE OVERHAUL BY GROB

There can be good reasons to modernize an existing machine or system instead of buying a new one. Identifying potential for improvement and successfully integrating new technologies into your company and products calls for an integrated analysis and professional implementation. Our experienced specialists develop suitable solutions for increasing the capacities of your GROB machines and help you decide which is more efficient – an overhaul or a new acquisition.



WE RESTORE YOUR MACHINE TO ITS TARGET CONDITION



After a few years, your GROB machine will not deliver the same accuracy and productivity as in the beginning due to wear.

Consequently, you are not far away from the decision to buy a new one. However, there are attractive alternatives for revitalizing your machine.

MANUFACTURING ACCURACY AND RELIABILITY, JUST LIKE ON DAY ONE!

A professional partial or complete overhaul of your GROB machine will restore performance to the level of a new machine, including a warranty for the entire scope of service.

Why choose an overhaul

OPTIMIZED PERFORMANCE AND PRODUCTION RELIABILITY

- ⊕ Upgrade your machine to state-of-the-art technology and restore the target condition.

NEEDS-BASED OVERHAUL

- ⊕ We offer you a tailored overhaul based on the actual condition of your machine.

BEST CONDITIONS

- ⊕ Access to all documentation required to carry out an efficient overhaul.
In addition, genuine spare parts can be accessed at any time.

COMPETENCE AND EXPERIENCE

- ⊕ Our technicians with years of experience know what is important.
You can also benefit from this in-depth knowledge for your next machine overhaul.

VALUE RETENTION

- ⊕ A retrofit or an overhaul will help you prolong your machine's useful life.
As a result, you get more from your investment and retain the value of your machine over the long term.

OVER 130 OVERHAULS PER YEAR – CARRIED OUT BY EXPERIENCED GROB PROFESSIONALS

Sometimes there are good reasons for modernizing an existing system or machine instead of buying a new one.



Hardware replacement

PCU RETROFIT

PCU REPLACED BY AN INDUSTRIAL PC (IPC)

- + For all GROB machining centers/linear gantries/transfer lines with a SIEMENS control system
- + PCU replaced by an industrial PC (IPC) running with Windows 10
- + Software modified to suit the new system

YOUR BENEFITS

- + Significantly less expensive than a complete upgrade from a control system
- + Maximum IT security thanks to the Windows 10 operating system
- + Familiar HMI with improved performance
- + Permits the use of additional software
- + Machine downtime of approx. one day
- + Option: Spare part availability of electrical components or preventive replacement of all critical electrical components



New control and drive components for machines with PowerLine control systems are generally no longer available. Trading in used components is also becoming increasingly competitive. We offer you two possible solutions. Both solutions provide you with a refurbished component in exchange for the defective one. All components have to pass a thorough function test prior to delivery. You also get an 18-month warranty on the exchanged components.

GET YOUR GROB MACHINE FIT FOR YEARS TO COME

For little investment, you can increase your IT security and guarantee a supply of spare parts over the long term.



PCU RETROFIT PROCEDURE

1. Prerequisite	GROB system with SIEMENS control system and PCU50
2. Software review by GROB's specialist department	Retrofit potential identified
3. Quotation / order	<ul style="list-style-type: none">• Fixed price quotation• Order placed by the customer
4. Preparation and testing on the GROB test bench	<ul style="list-style-type: none">• Machine-specific software modified• Software simulation on the new IPC on the GROB test bench
5. Pre-installation at GROB	Customer software (NC archive) is finally installed on the IPC
6. On-site implementation	PCU/MMC replaced by IPC, duration approx. 1 day

Option 1

SPARE PART AVAILABILITY OF ELECTRICAL COMPONENTS

The spare part availability of electrical components option guarantees you a suitable, immediate replacement should any electrical component fail. A scope of critical electrical spare parts to suit your needs is agreed between you and GROB. We guarantee you availability of the spare parts for your selected period, for example 10 years.

- ⊕ Assurance of spare part availability up until 2030, for example, even if discontinued by the manufacturer
- ⊕ Fixed and attractive exchange costs for the entire period
- ⊕ Spare part delivery within 24 hours*

* 24 hours within Europe for orders placed on weekdays before 5 pm .

Option 2

PREVENTIVE REPLACEMENT OF ALL CRITICAL ELECTRICAL COMPONENTS

We also offer the preventive replacement of all critical electrical components for all GROB machines.

- ⊕ Increased machine availability
- ⊕ Reduced machine downtimes
- ⊕ Attractive conditions

Hardware upgrade and software modification

NCU RETROFIT

If there is a lack of available spare parts for your discontinued hardware with outdated software and poor performance, an NCU retrofit would solve your problem.



- + Replacement of the current NCU with a newer NCU
- + Modification of the current software to a new system

NCU RETROFIT PROCESS

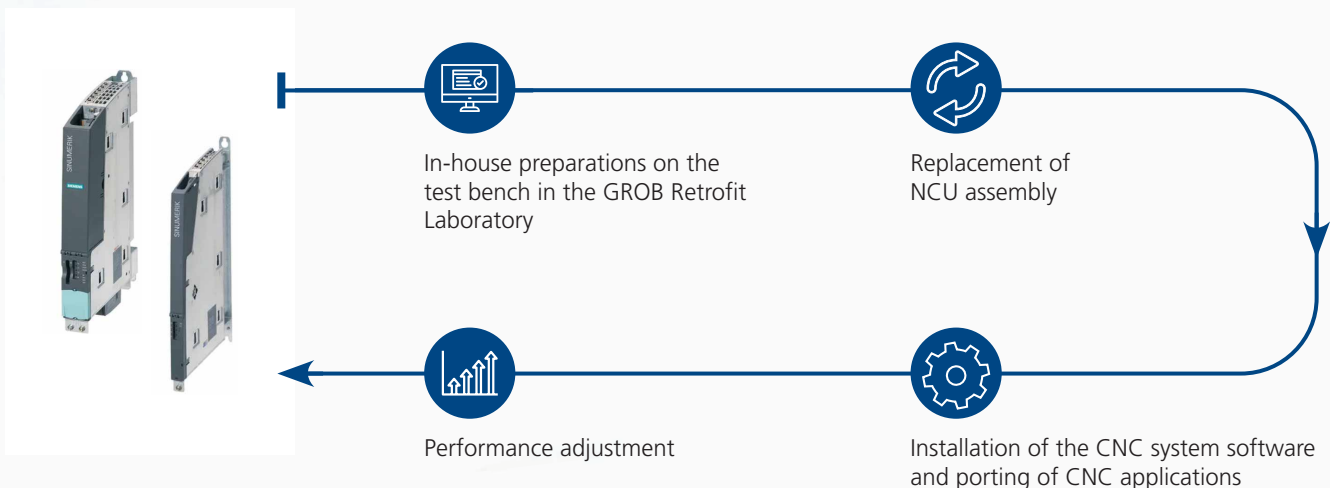

- + Machine downtime of 3 to 4 weeks: without GROB in-house measure
- + Machine downtime of around 3 to 5 days with preparation in the GROB Retrofit Laboratory

HOW AN NCU RETROFIT BENEFITS YOU

- + Possible cycle time reduction
- + Considerable cost and time savings compared to a complete control system upgrade
- + Spare part availability thanks to the new hardware
- + New functions due to the new software



We all know that time is money

NON-MACHINING TIME OPTIMIZATION

GROB NON-MACHINING TIME OPTIMIZATION STANDS FOR

- + 100 % transparency and manageability
- + You only pay what you save

We earn on every percentage point by which we shorten your cycle time for you. Fair and cooperative. The savings are especially attractive for machining processes with high non-machining times.

YOUR BENEFITS

- + Increasing the output quantity: More parts per time
- + Cost savings by reducing the unit costs
- + Saved machining times can be used for preventive maintenance work
- + The cost-benefit ratio can be clearly calculated and is transparent

REQUIREMENTS

G-Series development stage 5 machining technology with SIEMENS Solution Line, min. software version 2.6

EXAMPLE

Initial situation: 7.62 seconds non-machining time with conventional programming

- + After optimization non-machining time: 6.39 seconds
- + **Savings: 16 %**

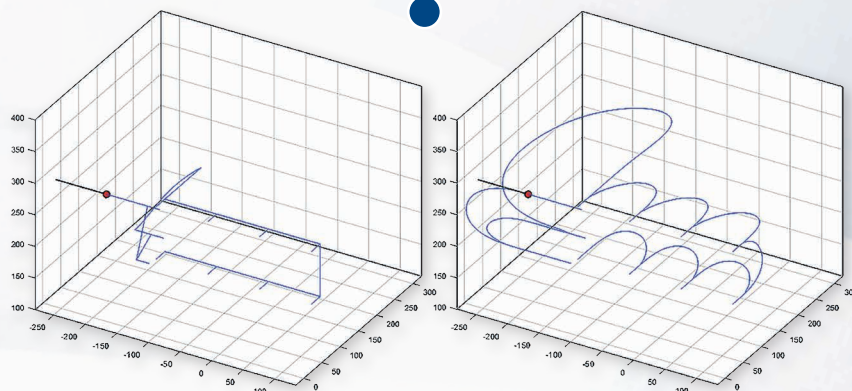

Make your machine state-of-the-art

RETROFITTING OPTIONS

The requirements on the machine can change over time, new safety standards may apply, or technological advancements are made. Retrofitting is a sensible option in these cases.

We modify or extend your machine to improve your performance, safety, and efficiency!

ALL BASED ON YOUR REQUIREMENTS

- + Laser measurement for milling tools (BLUM laser)
- + Optimization of machine kinematics (GSC)
- + Integration of external NC program memory (EES)
- + Automatic cutting fluid circulation
- + Automatic machine start and warm-up
- + Communication protocols, Industry 4.0 and IIoT
- + Additional flushing for volume cutting
- + MARPOSS collision monitoring (CMS)
- + Collision monitoring (DCM)
- + Close-to-spindle sorting (SNS)
- + Remote machine diagnostics (MFD)
- + Tool coding system (RFID)
- + Touch probe
- + Oil skimmer



You can find more details on our retrofit options in our separate retrofit options brochure

The ideal solution for your machine

AUTOMATION SOLUTIONS

STANDARD AUTOMATION

- + PSS-R100/PSS-R300
- + PSS-R450/PSS-R1800
- + PSS-L450/PSS-L2700
- + PSS-T300

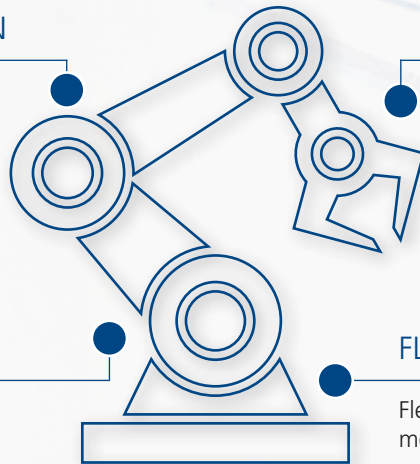

AUTOMATION SOLUTIONS

- + Digitalization – INDUSTRY 4.0
- + Service

FLEXIBLE ROBOT CELLS

- + GRC-R60 to GRC-R240
- + GRC-R12

FLEXIBLE MANUFACTURING SYSTEMS

Flexible manufacturing systems, autonomous mobile robot system, turnkey production lines



You can find more details on automation solutions in our separate automation brochure

SMART & EASY AUTOMATION

We will develop an automation concept with you that is **perfectly customized** to your requirements!

- + Increase output and productivity
- + Semi- or fully-automatic manufacturing with the highest quality standards
- + Digitalization and automation along the process chain



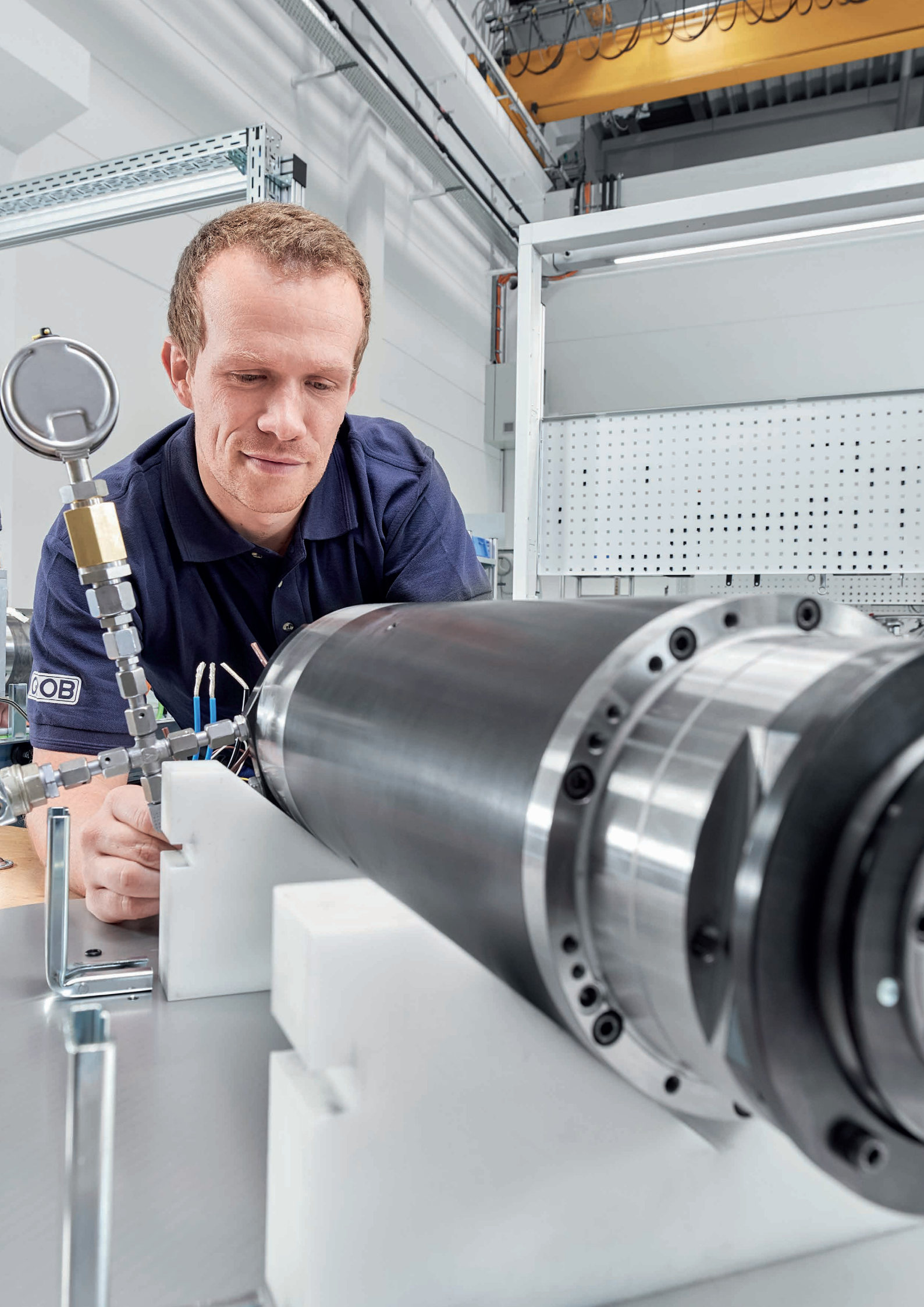



Fast, flexible, efficient

MOTORIZED SPINDLE SERVICE

With the various offers of the GROB spindle service, you are prepared for all eventualities and optimize your machine availability. Select the supply solution that suits your needs and benefit from our short response times and attractive conditions.

- ⊕ Your machine is down for the shortest possible time
- ⊕ 12 month warranty as for a new spindle
- ⊕ Maximum service life with manufacturer repair



OUR SERVICE PORTFOLIO

#ReplacementSpindleService #SpindleRepair
#SpindleHotel #SpindleReservation

Fast, flexible, efficient

MOTORIZED SPINDLE SERVICE

The various offers of GROB's spindle service prepares you for all circumstances and optimizes your machine availability. Select the supply solution that suits your needs and benefit from our short response times and attractive conditions.

YOUR BENEFITS

- + Immediate response after a motorized spindle failure thanks to our extensive replacement spindle warehouse
- + Your machine is down for the shortest possible time
- + Twelve-month warranty as for a new spindle
- + Maximum service life with manufacturer repair
- + Cost and time saving through special prices under a free service agreement

GLOBAL PRESENCE

Our global repair centers and spindle warehouses ensure fast and highly flexible motorized spindle service.



REPLACEMENT SPINDLE SERVICE



When every minute counts

The motorized spindle in your GROB machine has failed and needs to be replaced? Not a problem. We immediately take care of the delivery and installation of an overhauled spindle from our replacement spindle warehouse while our experts restore your defective spindle to working order in the GROB Repair Center.

PARTIAL SPINDLE REPAIR



Save up to 75 % on repair costs

Benefit from a flexible partial repair rather than a full one: In our Repair Center, we take care of the defective parts of your GROB motorized spindle and send the repaired spindle back to you via express shipping if necessary.

SPINDLE HOTEL



Professional storage

Do you have a replacement spindle but lack the right environment for storage and preventive maintenance? We have the solution: In the GROB Spindle Hotel, our experts store your replacement spindle in an optimal environment and take care of preventive maintenance and inspection if necessary.

SPINDLE RESERVATION



Highly flexible without replacement spindles

Fast support even without your own replacement spindle: With a spindle reservation, we guarantee an available replacement spindle from our in-house spindle pool at all times. Smooth replacement ensures minimum machine downtime.

**YOU FOCUS ON PRODUCTION –
WE TAKE CARE OF YOUR MOTORIZED
SPINDLES ANYWHERE IN THE WORLD!**

A motorized spindle failure costs time and money and causes irritation.
Make it easier for yourself with solutions from GROB.



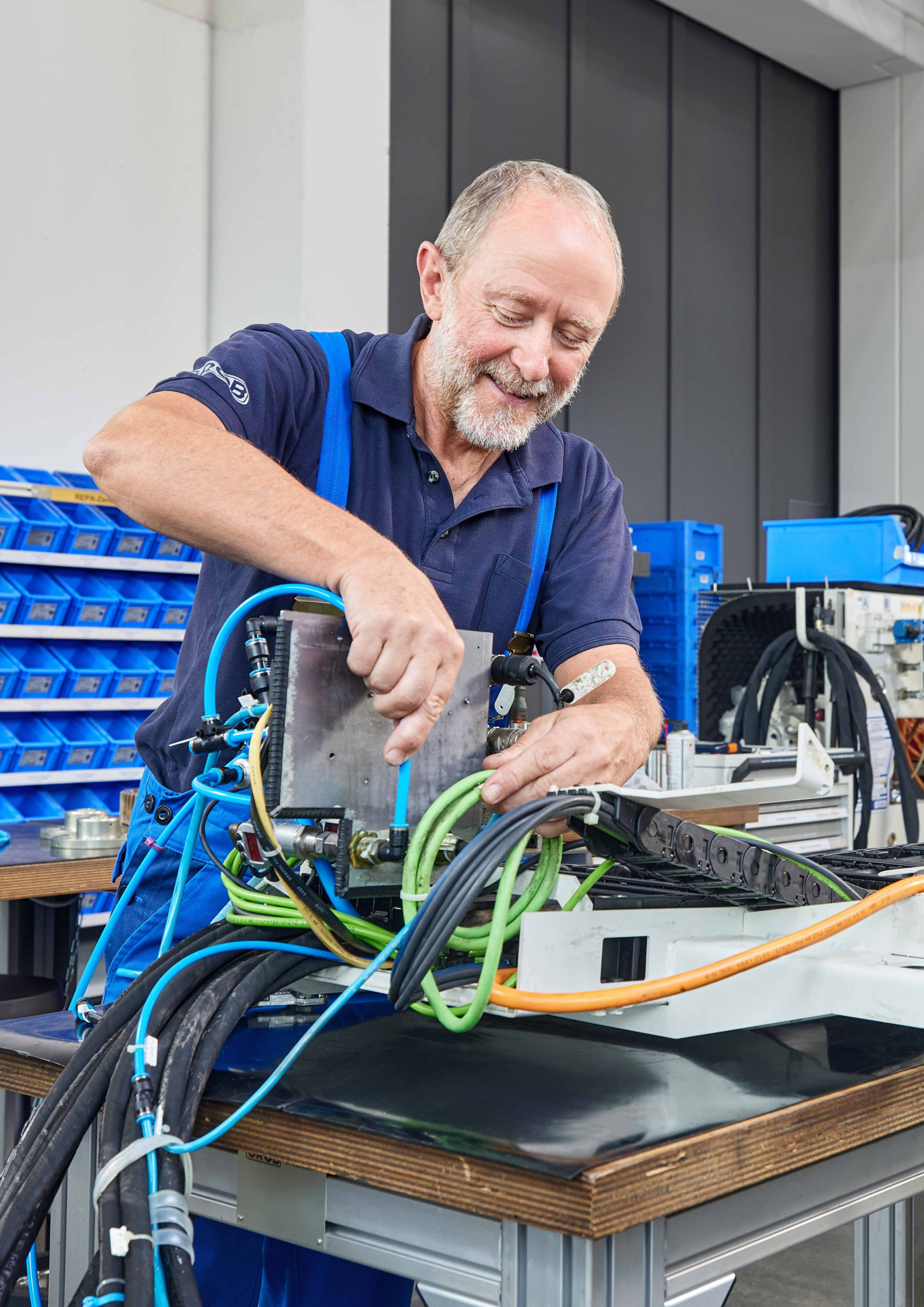



*Electrical as well
as mechanical systems*

IN-HOUSE REPAIRS

Whether rotary table, motorized spindle, or tool changer: In the GROB repair center we provide professional and fast repair of your machine components.

- ⊕ Experienced and qualified personnel
- ⊕ Original spare parts
- ⊕ Express processing
- ⊕ Refurbished components



OUR SERVICE PORTFOLIO

#RepairService #Mechanics

#Electronics #Assemblies #PartRepair

In good hands

ASSEMBLY AND PART REPAIRS

Repair service – mechanical systems

As with all our services, you get a one-to-one consultation even before a repair. During this process, we establish whether to carry out your repairs for a fixed price or according to the findings. In the case of the latter, we first examine and assess the components or the assembly. On the basis of these results, you then decide what is to be done and we repair according to your specific requirements, given the material availability, within just one week. For an unscheduled repair, GROB professionals can optionally carry out an express repair on-site.

- + Time and cost saving through efficient processes and large purchasing volume
- + Warranty of 12/18 months (also possible for the complete assembly)
- + Reliability and quality assurance by qualified personnel
- + Implementation of product improvements
- + Only original spare parts used
- + High spare part availability



Repair service – electronic systems

Are you experiencing difficulties maintaining electronic components in a swift and reliable manner?

Then we are the right partner for you, we consider ourselves a complete solution provider for mechanical and electronic components in the field of repair service as well.

- + Significant cost benefits with the same reliability
- + Quick and individual processing
- + 18-month warranty
- + Avoidance of compatibility problems or modification measures
- + Express provisioning without additional costs

FOR GROB AND THIRD-PARTY MACHINES

- + Procurement of rebuilt components or repair service
- + Complete function and performance check
- + Over 30,000 different rebuilt items constantly available from stock (SIEMENS, INDRAMAT, HEIDENHAIN, FANUC, and BOSCH)
- + Both current and discontinued materials
- + Motors, performance modules, CPU, NCU, etc.

YOU'RE IN GOOD HANDS WITH US...

...in the hands of a manufacturer with years of experience and extensive knowledge. Whether an individual component, assembly, or an entire GROB machining center – our specialists remedy tolerance faults or malfunctions quickly, competently, and for a fair price.



Reliable, just like on day one

REPAIR SERVICE FOR ELECTRONIC SYSTEMS

HAVE YOUR ELECTRONIC COMPONENTS SUDDENLY BEEN DISCONTINUED?

GROB refurbished spare parts are used products that undergo a quality-assured overhaul and maintenance for flawless reuse.

- + You save money and support sustainable production
- + You reduce your downtimes thanks to fast processing
- + You benefit from maximum manufacturer quality – as good as new

THIS IS WHAT WE OFFER YOU!

- + 1 to 3-day express processing
- + 30,000 available overhauled spare parts
- + 18-month warranty
- + Save up to 30% compared to the new spare part
- + Additional 30% discount for an exchange



The right machine at the right time

SCHEDULED VS. UNSCHEDULED REPAIRS

If a crash occurs, the machine may be out of operation for an extended period and a failure can be costly! We prevent this from happening with scheduled condition analyses and targeted repairs, and you benefit on a number of levels.

MACHINE DOWNTIME COMPARISON



Unscheduled repair

In a worst-case scenario, you can expect a machine downtime of between 8 and 20 weeks.



Scheduled repair

During a scheduled repair, we assume a maximum machine downtime of 2 weeks.

YOUR BENEFITS OF SCHEDULED REPAIRS

- + Minimized risk of failure
- + Considerably shorter downtime at a desired time
- + Scheduled condition analysis also includes measurements (in comparison to preventive maintenance)
- + Cost benefit, as the transport and delivery of several machines together is possible
- + The machine continues to operate as usual between the condition analysis and repair

WE RECOMMEND SCHEDULED REPAIRS WITH A PRIOR CONDITION ANALYSIS FOR MACHINES MORE THAN 6 YEARS OLD!

This allows our experienced technicians to schedule the repair of several machines. This takes place at your requested time and enables the efficient planning of personnel, material, and costs.







Quick problem-solving on site

FIELD SERVICE

We support you, whether you want to start production or are making comprehensive modifications to your machinery. On site, our highly qualified technicians are able to solve problems in an instant and quickly (re-)commission your GROB machine.

- ⊕ Fast
- ⊕ Competent
- ⊕ Sustainable



OUR SERVICE PORTFOLIO
#24/7Support #MaterialSupply
#MachineInspection

We can provide immediate assistance if necessary!

PRODUCTION SUPPORT

THE BENEFITS OF PRODUCTION SUPPORT

- + Reliable start of production
- + Remedy faults
- + Run in systems
- + Immediately eliminate machine downtimes
- + Access to second and third level support within GROB
- + Contact person – just-in-time and on site
- + Electrical expertise: Operation of BECKHOFF and TRUMPF lasers
- + Mechanical expertise: Assembly – Setup – Disassembly

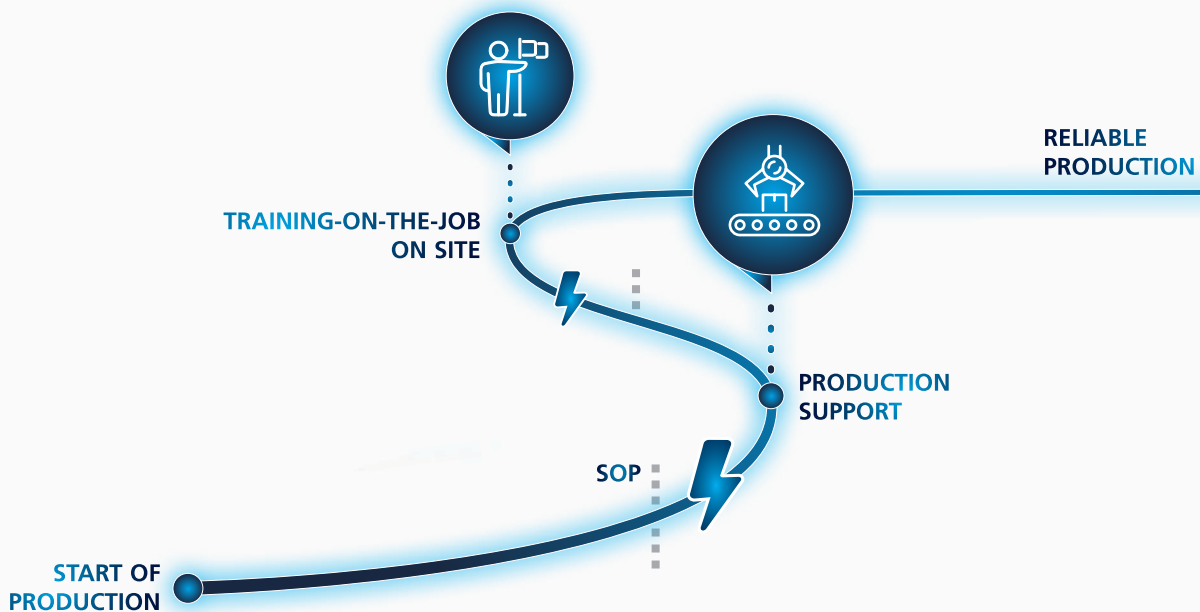

HOW YOU BENEFIT FROM PRODUCTION SUPPORT!

- + Rapid response time to machine downtimes
- + Immediate fault clearance on site
- + Consolidation of production targets
- + Our experts know your employees and the system



Seamless service from a single source

MACHINE RELOCATION

RELOCATION STEPS

- Overall planning/project management, even for subcontractors
- Disassembly by experienced and qualified experts
- Transport, incl. special equipment
- Foundation work at the new location
- Reassembly
- Geometry restoration
- Commissioning of the entire system
- Quality verification through process commissioning
- UVV and DGUV 3 testing, incl. documentation
- Training new personnel

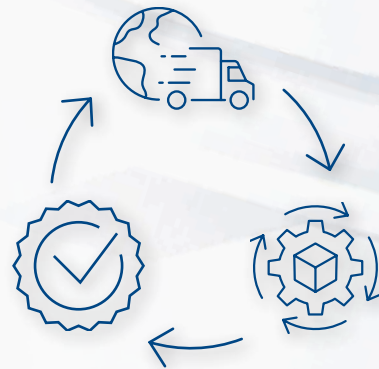

With high-quality equipment and competent experts.

OUR PROMISE TO YOU!

- ⊕ Thorough advance inspection and planning are automatically included as a matter of course
- ⊕ Decades of experience enable a seamless international relocation
- ⊕ Recommissioning by the manufacturer guarantees maximum quality standards





GROB





Moving into a digital future **INDUSTRY 4.0**

Transparency and connectivity – our modular GROB-NET⁴Industry web applications let you network and digitalize your production processes across all plants to make your production even more efficient. From planning to engineering to maintenance, GROB-NET⁴Industry combines relevant modules for increasing productivity and offers you a full service package for modern production in the Industry 4.0 era.

- ✦ GROB⁴AUTOMATION –
Intuitive production control software for unmanned operation



OUR SOFTWARE PORTFOLIO

#GrobNet4Industry #InteractiveApplication
#Cloud4Machine



Schnellsuche

G516-1920-0000-01 (Bürsteinheit)

Bauteil-Details

Informationen

Material-Nr. GROB: 1663

GROB Benennung: Decke

Menge: 1

ME: ST

ETV:

Icons

Hersteller

GROB

GROB

GROB

GROB

GROB

Teil

Bestell-Nr.

Typ-Bez.

System

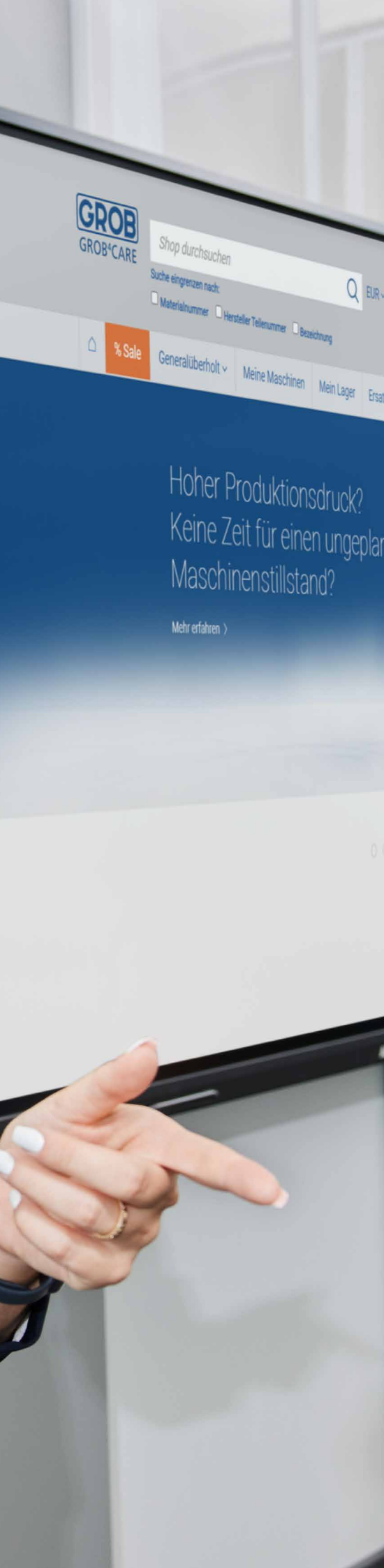

We demonstrate how to make optimum use of machines

GROB TECHNICAL ACADEMY

Aside from individual customer consultation and support, the GROB service range above all includes a wide range of instruction and training modules.

An experienced team of qualified training consultants provides instruction and training for all GROB product ranges, not only for universal machining centers and system solutions, but also for e-mobility.

- ⊕ Individually tailored to your needs
- ⊕ Permanently qualify your employees
- ⊕ Every employee receives a certificate after successful participation



OUR ACADEMY PORTFOLIO

#Assembly #E-mobility #SystemSolution
#UniversalMachiningCenters #GROB⁴Pilot

Moving into a digital future

GROB TECHNICAL ACADEMY

As products become more and more complex and the competition gets tougher, the importance of customer training as a key component of the GROB global range of services is constantly growing.

An experienced team of qualified trainers is meeting this challenge at GROB.

INDIVIDUAL TRAINING OPPORTUNITIES WITH GROB

It will be our pleasure to prepare a training concept to meet your specific needs. We do this by analyzing your needs to develop a tailored course that fulfills your personal aspirations.

Please submit your training inquiry/booking to:

E-mail: training@grob.de · Phone: +49 8261 996-5771

Further information about your training is available at:

<https://www.grobgroup.com/service-schulungen/kundenschulungen>



Assembly & e-mobility

- + Operation
- + Transport systems
- + Electrical maintenance
- + Mechanical maintenance
- + SIEMENS TIA basic course of the GROB structure
- + BECKHOFF basic course on the GROB structure
- + Basic principles of robots on GROB systems

System solutions

- + NC programming (GROB-specific programming)
- + Operation
- + Electrical maintenance
- + Mechanical maintenance
- + Motorized spindle mechanical systems (installation and removal)
- + RENISHAW (perpendicularity), mechanical systems
- + Tool change – mechanical systems

Universal machining centers

- + Operation
- + NC programming, basic course
- + NC programming – swiveling
- + NC programming advanced courses
- + Mill-turn technology
- + Touch probe programming
- + GROB pallet storage systems (PSS-R/PSS-L)
- + Course for switching from HEIDENHAIN iTNC 530 to TNC 640
- + Electrical maintenance

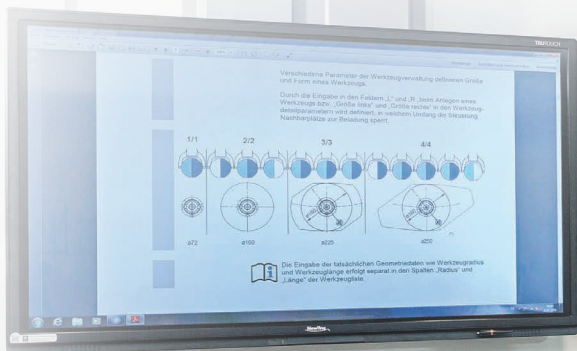

Perfect addition to production support

TRAINING-ON-THE-JOB

THE BENEFITS OF TRAINING-ON-THE-JOB

- + Qualify maintenance
- + Analyze faults
- + Stabilize the system
- + Prevent machine downtimes
- + Access to second and third level support within GROB
- + System-specific competence: mechanical & electrical
- + Develop problem-solving competence
- + Establish and supervise shop floor meetings and documentation: 8D, FMEA, RCA, etc.

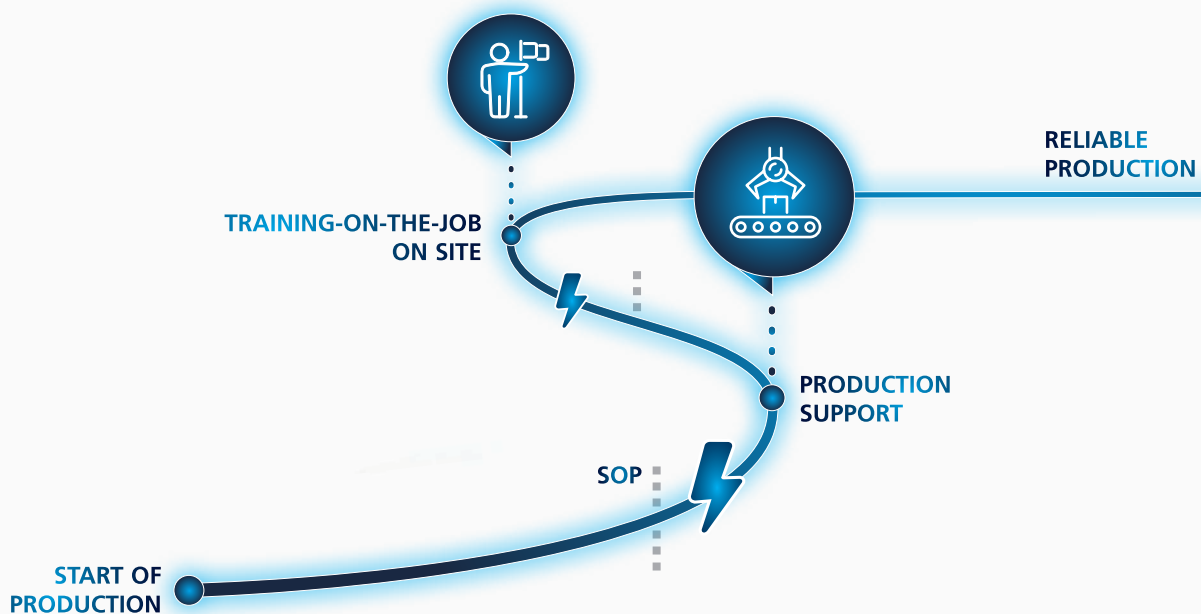

YOUR BENEFITS OF TRAINING-ON-THE-JOB!

- + Strengthening of individual maintenance competence
- + Understanding & lasting correction of faults
- + Stabilization of internal workflows and production
- + A highly qualified contact person on site



Learn when and where you want

GROB CAMPUS



The GROB Campus gives you the opportunity to flexibly expand your skills to meet your requirements at any time. This ensures that you are perfectly prepared for your future challenges.

Expand and enhance your knowledge with customized digital training offers!

WHAT IS THE GROB CAMPUS?

- + Innovative learning management system
- + Targeted learning and expertise management
- + Provision of digital learning content such as online courses or videos
- + Digital training catalog on our training offer



Learning management

View the GROB training courses that your employees have already completed at any time.



Expertise management

Central management of expertise to close current and future knowledge and skill gaps.



Digitalization

Learn when and where it best suits your company and your employees.



We help you maximize your success!

SKILL GAP ANALYSIS

OVERVIEW OF THE PROCESS

Our Skill Gap Analysis paves the way to customized training concepts. It identifies potentials and areas in which qualification requirements exist. This lets us come together for targeted further development.



FROM THIS, WE DERIVE...

- + ...where knowledge can help to accelerate production
- + ...how knowledge can reduce non-machining times
- + ...where processes can be structured more efficiently

EXAMPLE ACTUAL STATE OF A GROUP OF EMPLOYEES

Preparation of an individual matrix to illustrate employee knowledge

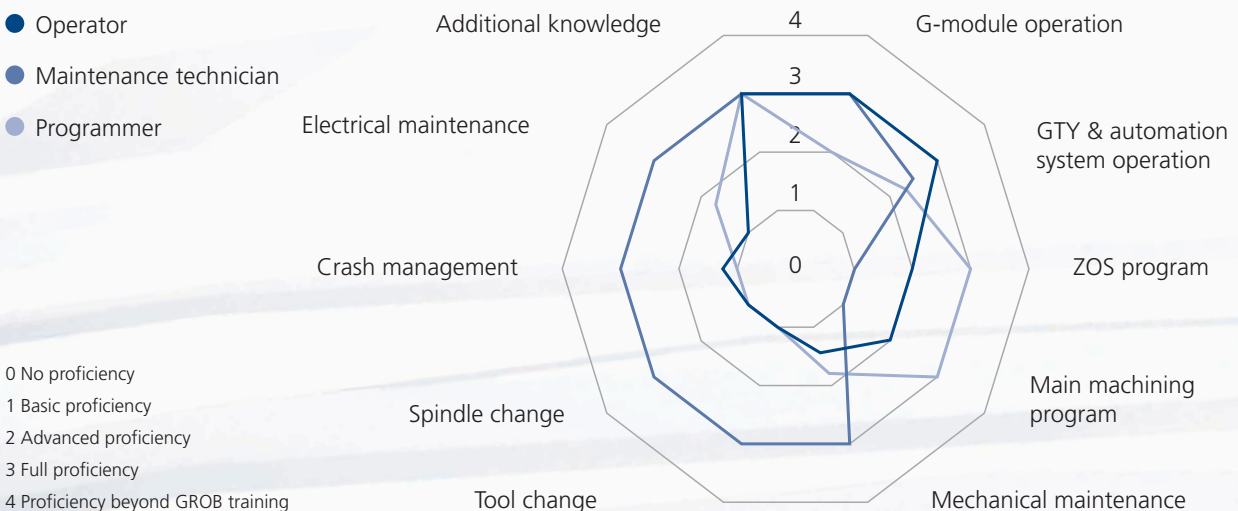



OUR MEASURES

Depending on the existing employee knowledge, the following training courses are offered in addition to **production support** and **training-on-the-job**: Basic Training, Advanced Training, and Expert Training

Your benefits

- ⊕ Obtain a new perspective of your internal processes
- ⊕ Targeted measures can be individually initiated
- ⊕ Clear measurability of increases in efficiency

EXAMPLE: MINIMAL TRAINING

Production support (3 months)	1x Basic Training (3 days)	1x Advanced Training (5 days)	8x Expert Training (5 days)
----------------------------------	-------------------------------	----------------------------------	--------------------------------

EXAMPLE: SUSTAINABLE TRAINING

Production support (4 months)	2x Basic Training (3 days)	2x Advanced Training (5 days)	8x Expert Training (5 days)
Training-on-the-job (6 months)	+ Special training documents		

Worldwide throughout the machine service life

GROB – GLOBAL AND INTERNATIONAL

From Bavaria to the world: Since our founding in 1926 in Munich, we as a global, family-managed company have been on a constant growth trajectory developing and manufacturing systems and machine tools. Our customers include the world's leading automotive manufacturers, their suppliers, and renowned companies from the aerospace, mechanical engineering, and other industries. With our production facilities in Germany, Brazil, the USA, China, Italy and India, as well as 15 worldwide service centers and sales branches, we are represented around the globe, ensuring the highest quality.

FOUNDED IN 1926

NORTH AMERICA

Bluffton, Ohio, USA
Detroit, Michigan, USA
Querétaro, Mexico

6 PLANTS

15 SALES
AND SERVICE BRANCHES WORLDWIDE

SOUTH AMERICA

São Paulo, Brazil

Our global production sites



Mindelheim, Germany



São Paulo, Brazil

EUROPE

Mindelheim, Germany
Pianezza, Italy
Stratford-upon-Avon, Great Britain
Hengelo, Netherlands
Senlis, France
Baar, Switzerland
Poznań, Poland
Győr, Hungary
Istanbul, Turkey

24/7 SUPPORT



ASIA

Dalian, China
Bangalore, India
Beijing, China
Shanghai, China
Yokohama, Japan
Suwon, South Korea
Haiphong, Vietnam
Bangkok, Thailand



Bluffton, USA



Dalian, China



Pianezza, Italy



Bangalore, India





www.grobgroup.com

© GROB-WERKE GmbH & Co. KG - 04/2024/EN

GROB-WERKE GmbH & Co. KG

Pioneers in designing and building highly innovative production and automation systems for almost 100 years.

*#MachiningTechnology #UniversalMachiningCenters
#AssemblyPlants #Electromobility #Automation
#AdditiveManufacturing #Digitalization
#NewAndQualityCheckedUsedMachines #Service*



Stay informed and
subscribe to the
GROB Newsletter now!



Excellence in sustainable technology